

Operating manual

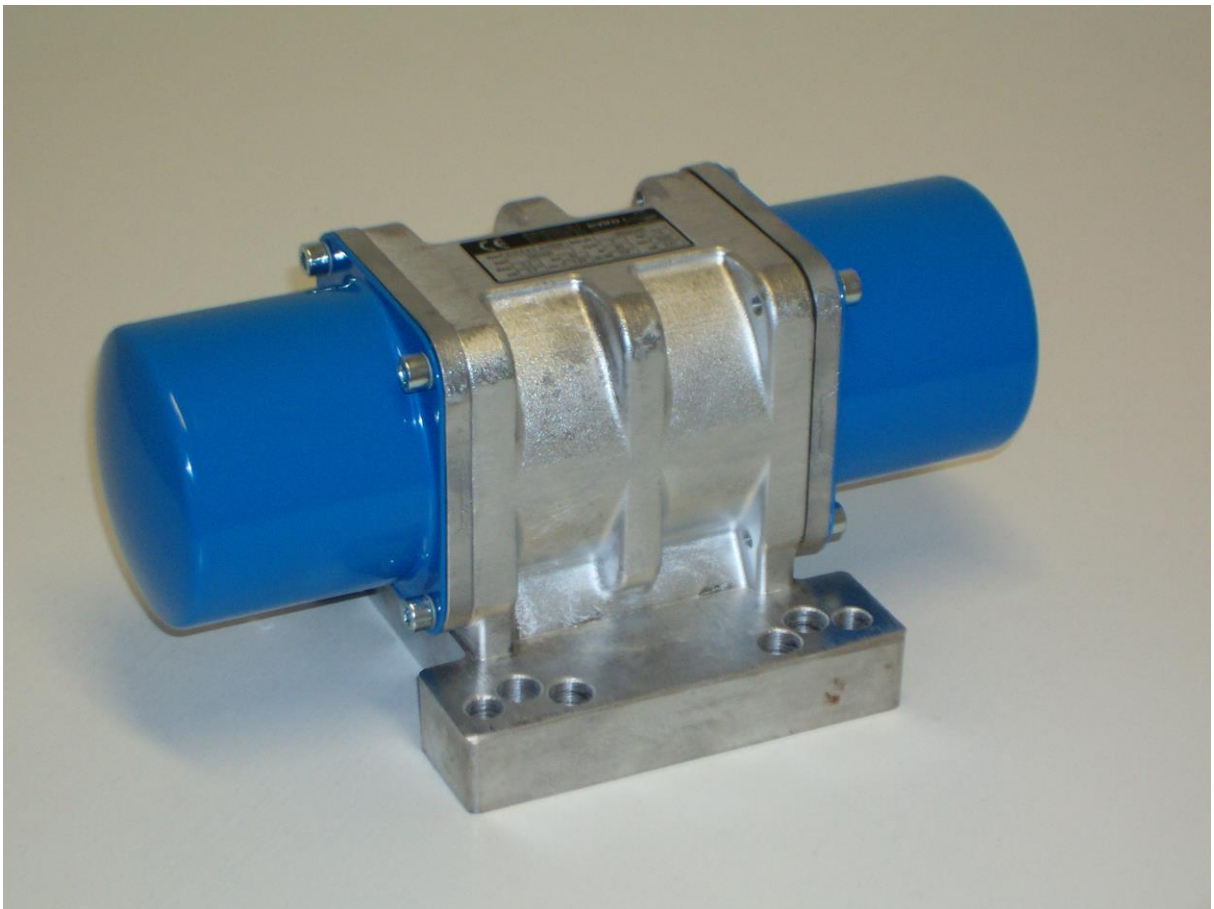

eviro vibration motors series A10 / AE10 / AEH10 / ANH10

ID no.:18.80.000.010100
Issue date: 01.10.2018
Rev. no.: 07



1. Content

1.1. Table of contents

1. Content.....	2
1.1. Table of contents	2
1.2. List of figures	2
1.3. Annexes.....	2
1.4. Explanation of the symbols used in the operating manual	3
2. Identification	4
2.1. Name and address of the manufacturer.....	4
2.2. Type designation.....	4
2.3. Declaration of conformity	5
3. Product description.....	6
3.1. General functions and application area, intended use	6
3.2. Technical data	6
3.3. Ambient conditions for storage and operation.....	8
3.4. Safety information	8
4. Preparing the product for use	9
4.1. Transport and storage.....	9
4.2. Safety measures before use	10
4.3. Installing and mounting	10
4.3.1 Mechanical installation	10
4.3.2. Electrical installation.....	12
5. Operating manual.....	15
5.1. Safe operation / safe function	15
5.2. Normal function.....	16
5.3. Adjustment of the centrifugal force of the vibration motor	16
6. Maintenance and repair.....	18
7. Decommissioning of the product	19
Exploded view	20
Spare parts list	21





1.2. List of figures

Figure 1 Type plate	5
Figure 2 Motor dimensions.....	6
Figure 3 Mounting of vibration motors	11
Figure 4 Terminal box allocation	13
Figure 5 Execution of the electrical connections in the terminal box	13
Figure 6 Cable installation connection line	15
Figure 7 Adjustment of centrifugal weights.....	17

1.3. Annexes

- Annex 1 – Spare parts list
- Annex 2 – Exploded view
- Annex 3 – Declaration of conformity

1.4. Explanation of the symbols used in the operating manual

NOTE	
	This symbol identifies instructions and notes for the intended use of the product. These instructions and notes have to be observed by the user of the product.
⚠ WARNING	
	This symbol indicates the possibility of severe or irreversible injuries caused by possible dangerous situations.
⚠ DANGER	
	This symbol indicates the possibility of mortal, severe or irreversible injuries caused by the direct hazard of touching high voltage-carrying parts.
⚠ DANGER	
	This symbol indicates the possibility of mortal, severe or irreversible injuries caused by the direct hazard when operating the product in an explosion-prone environment.
	This symbol requests the user of the product to interrupt the mains connections before carrying out any work at the product or machines, plants and devices which are connected to the product, and to secure the connection against unintended reconnection.

2. Identification

2.1. Name and address of the manufacturer

eviro Elektromaschinenbau &
Metall GmbH Eibenstock
Muldenhammerstraße 5
D-08309 Eibenstock



Phone: +49 (0) 37752 / 3013
+49 (0) 37752 / 3035
Fax: +49 (0) 37752 / 3057
E-Mail: info@eviro.com
Internet: www.eviro.com



For many years, the company eviro Elektromaschinenbau & Metall GmbH Eibenstock has been developing and producing vibration motors as well as complete modules for electrical drives which live up to the highest quality standards. Its reputation as an innovative and flexible manufacturing company is valued by the customers and many users of the products made by eviro.

2.2. Type designation

The present operating manual refers to vibration motors of the series **A 10 – x/x** by the company eviro Elektromaschinenbau & Metall GmbH Eibenstock from the **serial number 16nnnnnn**. The corresponding information is given on the type plate of the motor. The type plate is located on the cover of the terminal box. Additionally, the serial number is also embossed in the motor housing below the terminal box.

The information given on the type plate are explained below.

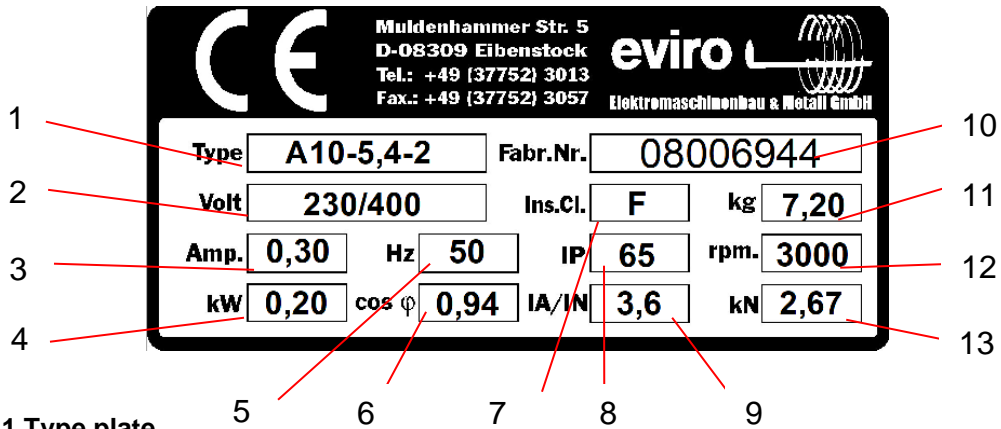

Figure 1 Type plate

- | | | |
|---|--------|---|
| 1 - Type designation | A | → Stator housing made of aluminium casting |
| | E | → Enhanced bearings used |
| | N | → Low voltage |
| | H | → High frequency version |
| | 10 | → Designation of the series |
| | 5,4 | → Working torque in kgcm for series A10
centrifugal force in kN for series AEH10/ANH10 |
| | 2 | → 2-pole |
| | K | → Connection cable mounted at the factory |
| | 010005 | → Item number company eviro |
| 2 - Rated voltage in V (Δ / Y) | | |
| 3 - Rated current at rated speed in A | | |
| 4 - Power consumption in kW | | |
| 5 - Rated frequency in Hz | | |
| 6 - Power factor $\cos\phi$ | | |
| 7 - Heat insulation class F (150°C) | | |
| 8 - Ratio starting current – rated current | | |
| 9 - Type of protection IP65 | | |
| 10 - Serial number | | |
| 11 - Weight in kg | | |
| 12 - Rated speed in rpm | | |
| 13 - Centrifugal force at rated speed in kN | | |

2.3. Declaration of conformity

Details on the conformity with the applicable European guidelines and harmonized standards are enclosed to this operating manual in Annex 3.

Vibrating motors do not comply with Article 1, subsection 2, point "k" of Directive 2006/42/EC (Machinery Directive).

3. Product description

3.1. General functions and application area, intended use

The vibration motors of the types A10 are intended for the special use in machines and devices, in which centrifugal forces have to generate vibrations with frequencies of up to 60 Hz (30 Hz with 4-pole design, 20 Hz with 6-pole design), for the types AEH10 / ANH10, up to 100 Hz.

They are characterized by their compact construction and they have particularly wear-resistant and knock-out-safe bearing shields made of grey cast, and an aluminium stator housing. Therefore, they can be used in a wide operating temperature range.

During use, it must be ensured that the effective value and the frequency of the operating voltage of the motor must not exceed the values stated on the respective type plate (see Figure 1 Type plate) at any time!

Vibration motors with additional "C" in type designation are special "low-cost" types with housings made by sand casting. They are not noise optimized.

Inappropriate use and disregarding of the instructions in this manual is considered an abuse and is not permitted. In this case, the manufacturer is free from any direct or indirect responsibility.

Vibration motors must not be operated alienated to drive rotating machine or plant components!

NOTE	
	<p>Machines or devices into which the motors of the series A10 are installed, may only be put on the market if their conformity with the guideline 2006/42/EC (machinery directive) or equivalent technical guidelines or national regulations in the applicable version was proven.</p>

3.2. Technical data

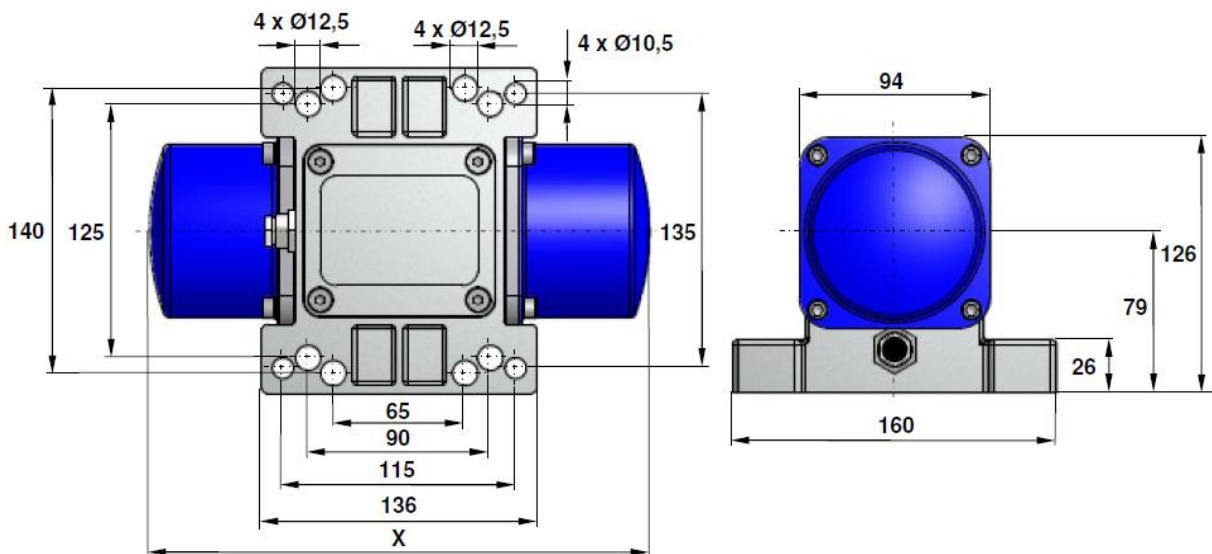

Figure 2 Motor dimensions

vibration motors A10 / AE10 / AEH10 / ANH10												
Type	Working torque	Centrifugal force	Rated voltage	Power consumption	Rated current	Power factor	Ratio starting- / rated current	Rated mains frequency	Max. speed (at fN)	Number of poles	weight	Motor length
	M _A	F	U _N	P	I _N	cosφ	I _A /I _N		n		m	X
	[kgcm]	[kN]	[V]	[kW]	[A]			[Hz]	[min ⁻¹]		[kg]	[mm]
A10-1,7-2/ AE10-17-2	1,7	1,23	400	0,20	0,52	0,94	3,6	60	3600	2	6,0 6,1	209
A10-2,8-2/ AE10-2,8-2	2,5	1,23	400	0,20	0,30	0,94	3,6	50	3000	2	6,0 6,1	209
A10-3,7-2/ AE10-3,7-2	3,7	2,67	400	0,20	0,52	0,94	3,6	60	3600	2	7,1 7,2	249
A10-4,2-2/ AE10-4,2-2	4,2	2,87	400	0,20	0,52	0,94	3,6	60	3600	2	7,2 7,3	249
A10-5,4-2/ AE10-5,4-2	5,4	2,67	400	0,20	0,30	0,94	3,6	50	3000	2	7,1 7,2	249
A10-6,0-2/ AE10-6,0-2	5,8	2,87	400	0,20	0,30	0,94	3,6	50	3000	2	7,2 7,3	249
A10-5,8-4/ AE10-5,8-4	5,8	1,03	400	0,18	0,34	0,78	3,6	60	1800	4	8,0 8,1	281
A10-9,0-4/ AE10-9,0-4	8,3	1,03	400	0,18	0,34	0,78	2,3	50	1500	4	7,2 7,3	281
A10-5,8-6	5,8	0,32	400	0,2	0,7	0,55	2,5	50	1000	6	7,1	247
A10-8,3-6	8,3	0,46	400	0,2	0,7	0,55	2,5	50	1000	6	8,0	280
AEH10-7,8-4		6,57	250	0,60	1,65	0,80	1,9	200	6000	4	6,5	249
AEH10-7,8-4		6,57	110	0,65	6,7	0,52	7,8	200	6000	4	6,5	249
ANH10-7,8-4		6,57	42	0,4	7,30	0,75	5,2	200	6000	4	6,5	249

Table 1 Technical data

	Admissible maximal mains frequency 50 Hz
	Admissible maximal mains frequency 60 Hz
	Admissible maximal mains frequency 200 Hz

3.3. Ambient conditions for storage and operation

	Storage	Operation
Temperature min.	-20°C	-20°C
Temperature max.	60°C	40°C
Rel. humidity max.	60%	80%

Table 2 Permissible ambient conditions for storage and operation

The motors of the series A10 / AE10 / AEH10 / ANH10 must **not** be used in an explosion-prone area. They are dustproof and water jet-proof according to the type of protection IP65 pursuant to EN 60529 (VDE 0470 /DIN IEC 34, part 5).

3.4. Safety information

NOTE	The present manual has to be read carefully. In doing so, the safety instructions and warning notices have to be observed in particular. At the same time, the applicable national subject-specific safety and accident prevention regulations have to be observed! This operating manual has to be kept in a safe place!
	

⚠ DANGER	The motors of the series A10 / AE10 / AEH10 / ANH10 must not be used in an explosion-prone area.
	

	Before carrying out any work at the vibration motor or the machine, plants and devices connected to the vibration motor, the mains connections have to be interrupted and secured against unintended re-connection. Metal surfaces which might be touched have to be earthed.
---	--

Work on the electrical installation of the vibration motor may only be carried out by specialist electricians.

For electrical work, only voltage isolated electrician tools which comply with the respective national standards and regulations (VDE) may be used.

Any material used for the electrical connection of the vibration motor has to comply with the applicable national standards and regulations.

The mains voltage and the mains frequency have to comply with the respective specifications on the type plate of the vibration motor.

The vibration motor must not be touched during operation!

⚠ WARNING		While plant components are active, avoid areas in which contact with moving parts of the machine might occur. Before entering such an area, the plant has to be switched off and a switch-off or securing process has to be carried out in accordance with the specifications of the plant manufacturer. Staying on plant components subject to vibration is strictly forbidden.
		Vibration motors can reach an operating temperature of 90 °C during operation. The vibration motor must not be touched during operation. Before touching it, switch off the motor and allow it to cool down! Risk of burning!

NOTE		Every intervention in the vibration motor which was not described in this manual will void the safety of the vibration motor and its conformity with the applicable guidelines, standards and rules. This leads to a loss of guarantee and releases the manufacturer from any liability for possibly occurred damages.

4. Preparing the product for use

Before carrying out any work at the vibration motor or the machine at which the motor is mounted or shall be mounted, it must be ensured that neither the vibration motor nor the machine is damaged.

4.1. Transport and storage

The vibration motor has to be checked for visible transport damages upon delivery.

NOTE		If the motor shows visible external damages, it must not be taken into operation under any circumstances and must be returned to the manufacturer for inspection and repair. Unauthorised interventions in the motor, except the ones described in this manual, are prohibited!

Storage may only be effected in dry rooms.

For the storage, the allowed ground and bearing loads of the storage location have to be observed. It is not allowed to pile up motors or to store other items on the motor. The allowed ambient conditions for the storage of the vibration motors are described in table 2 of this manual on page 8.

In order to transport individual motors by hand, or within the framework of the assembly process of the motor, it may only be lifted at the stator housing in order to avoid deformations of the protective covers or other components.

⚠ DANGER	
	The motor must not be lifted at already assembled electrical connection cables under any circumstances. This can cause unsafe electrical connections and cable breaks.

4.2. Safety measures before use

Before use, the motor has to be checked for external damages.

NOTE	
	If the motor shows visible external damages, it must not be taken into operation under any circumstances and must be returned to the manufacturer for inspection and repair. Unauthorised interventions in the motor in this regard are forbidden!

For a cable connection which was pre-assembled by the manufacturer, the cable has to be checked for possible damages caused by the transport, and the fixed mounting of the connection line in the terminal box gland of the vibration motor has to be verified.

4.3. Installing and mounting

4.3.1 Mechanical installation

In compliance with the generally known principles of function and operation modes of rotating unbalance vibration exciters, the installation position of the eviro vibration motors is arbitrary. The surface provided for the assembly has to be level and torsion-resistant. For the assembly of the motor at the mounting surface, use screws M10 or M12 of the quality 8.8 depending on the used drill pattern, or better according to DIN EN ISO 4014 (DIN 931), DIN EN ISO 4017 (DIN 933) or DIN EN ISO 4762 (DIN 912), and if required, hex nuts of the quality 8.8 or better according to DIN EN ISO 4032 (DIN 934). 4 screw points of the motor have to be used respectively. The screwing has to be effected regularly, and alternately crossed using a torque wrench. The tightening torques according to table 3 have to be applied.

Thread marking	Tightening torque
M4	2,9 Nm
M8	23 Nm
M10	47 Nm
M12	80 Nm

Table 3 Required tightening torques for screws (quality 8.8)

For a direct screw connection with the mounting surface, the effective thread length in the un-tempered underground structure (St37) has to be at least twice the screw diameter in mm.

The screw connections have to be mechanically secured against unintended loosening (e.g. by attaching a Schnorr lock washer S20). The tight fit of the screws has to be checked in particular during the initial operating time.

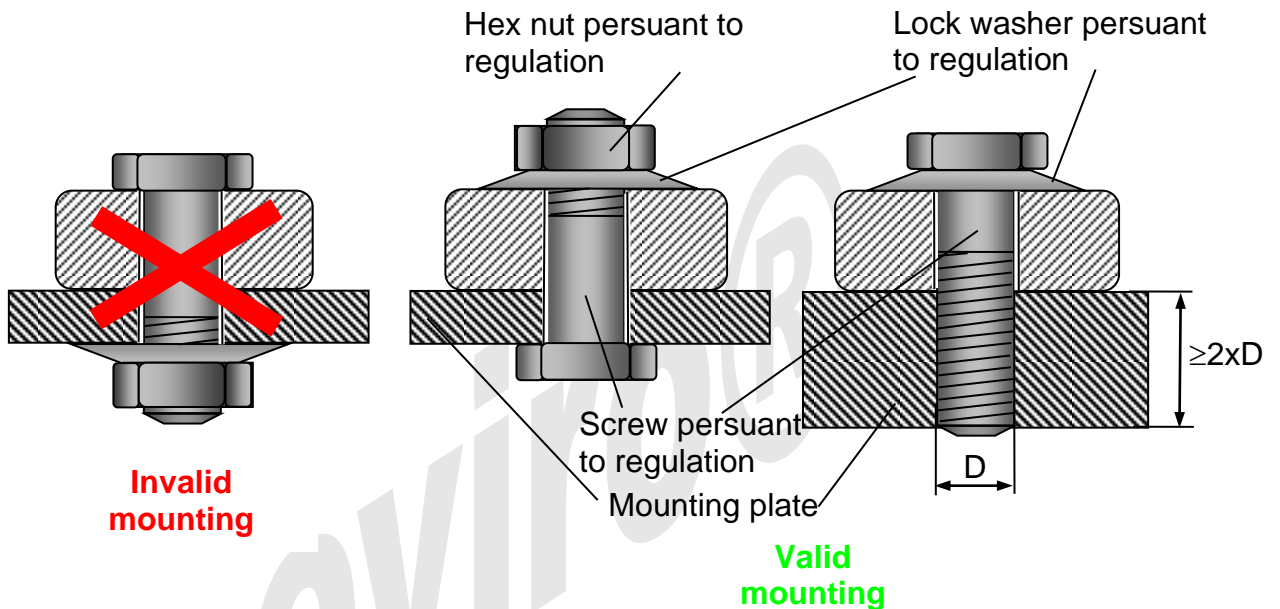



Figure 3 Mounting of vibration motors

Alternative mounting methods have to be agreed with the manufacturer and are only allowed after the written consent of the manufacturer.

Note	
	Used lock washers must not re-used after disassembly but have to be replaced by new ones!

4.3.2. Electrical installation

⚠ DANGER	Work on electrical equipment may only be carried out by respectively instructed specialist personnel. Only voltage isolated tools may be used.
	

In order to establish the electrical connections of the vibration motor, only use flexible cables **HO7RN-F 4G1.5** or equivalent. When operating the vibration motor at an electronic frequency converter, the cable specified by the manufacturer of the frequency converter has to be used. Possibly required shielding has to be connected at the earthing point of the earth wire.

The connections have to implement pursuant to DIN VDE 0100. The connecting cable has to be guided into the terminal box by means of the cable gland. The sheath insulation has to project into the terminal box. In doing so, ensure the tight fit of the cable sheath in the screw connection in order to prevent a rubbing of the cores at the thread hole! In order to connect the individual cable cores, they have to be stripped to approx. 8 mm. Using special crimping pliers, the crimp terminals M4 have to be crimped for a core cross-section $\geq 1.5\text{mm}^2$ (blue). The installation of the wires in the terminal box has to be effected in such a way that they do not contact the terminal box housing and that they are guided to the terminal board bolt in short arches in order to prevent self-oscillations of the cables as far as possible.

NOTE	It is forbidden to coat the cable cord with tin for contacting, or to solder on cable lugs!
	

The green-yellow earth wire (USA: single colour green) has to be mounted on the clamping point marked with the earth symbol. The required small parts for the establishment of the electrical connections are packed in the connection bag which is located in the terminal box upon delivery. The tightening torques of the electrical screw connections have to be 2.9 Nm. With the terminal box wiring shown in figure 3, a positive rotation of the motor results (counter-clockwise rotation).

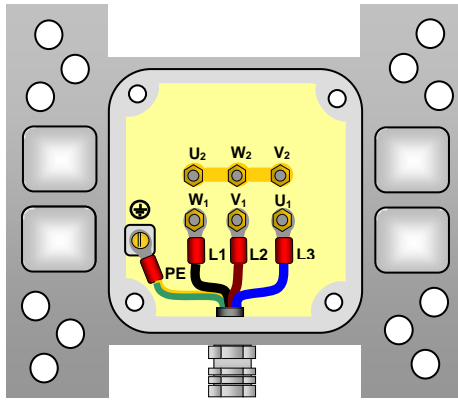

3*400V Y-Wiring

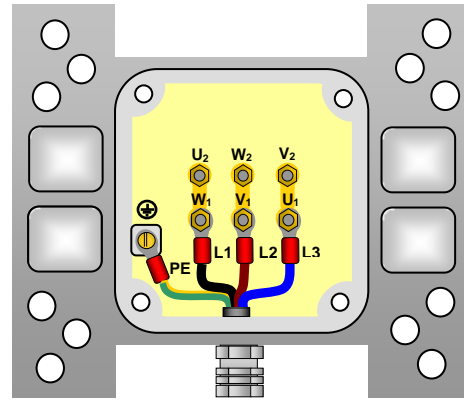

3*230V Δ-Wiring

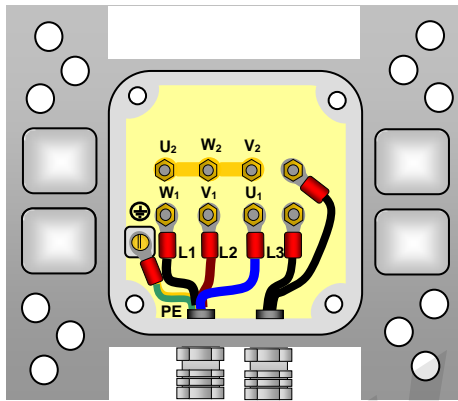

3*400V Y-Wiring with included PTC thermistor (using special housing with 2 cable glands)

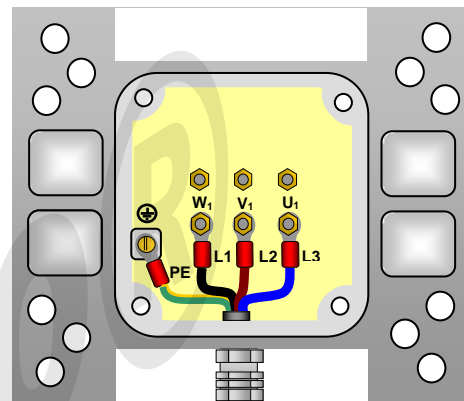

AEH10 / ANH10

Figure 4 Terminal box allocation

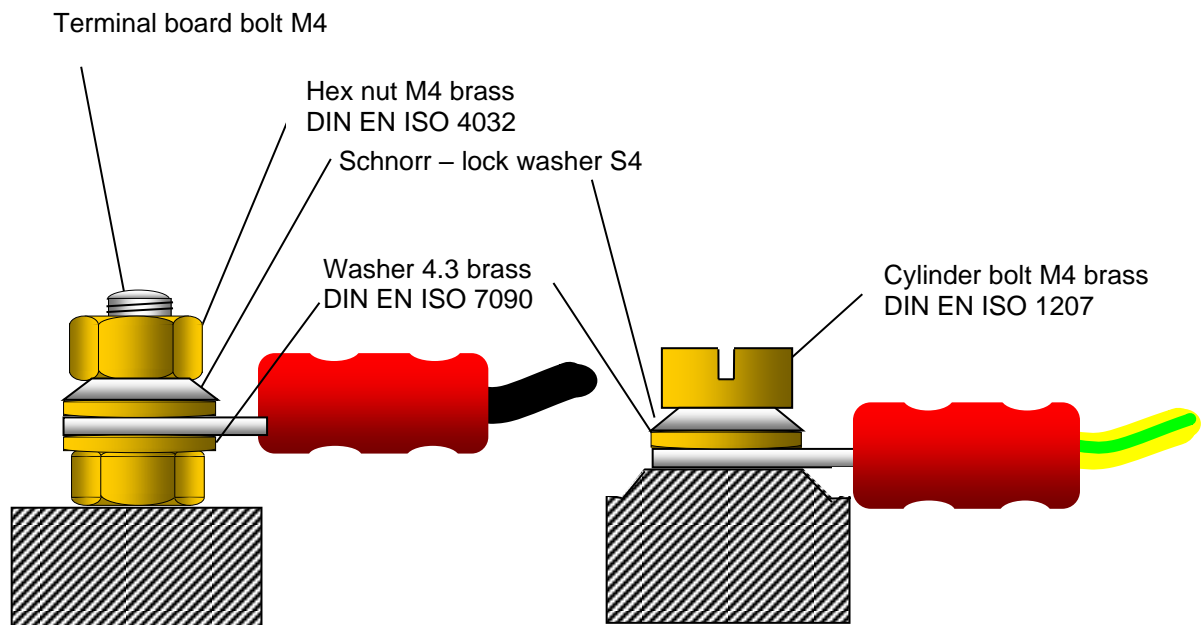



Figure 5 Execution of the electrical connections in the terminal box

After executing the electrical connections, the terminal box sealing has to be attached and the terminal box has to be closed using the terminal box cover. In order to do so, you have to ensure the intactness of the terminal box sealing. Damaged seals have to be replaced.

Every vibration motor has to be operated on a suitable motor circuit breaker. In doing so, rated and start-up current of the motor pursuant to the specifications on the type plate (see Figure 1 Type plate) have to be observed in particular. The connection has to be established according to DIN 57100 (VDE 0100).

When operating the motor on an electrical frequency converter, the respective manual has to be observed. If necessary, suitable measures in order to observe the applicable EMC regulations have to be taken. If the frequency converter contains the motor protection function, the use of a motor circuit breaker is not necessary. In particular, it has to be ensured that the effective value and the frequency of the operating voltage of the motor do not exceed the values stated on the type plate (see Figure 1 Type plate) at any time!

⚠ WARNING	<p>Effective values and frequencies of the operating voltage which are higher the values specified on the type plate can cause the destruction of the motor or the machine on which the motor is assembled.</p>
	

Note	<p>Used lock washers <u>must not</u> be re-used after disassembly but have to be replaced by new ones!</p>
	

The cable installation at the machine or plant on which the motor is assembled has to be effected in such a way that no self-oscillations of the connection line can occur when operating the motor. The cable has to be protected against contact with sharp components.

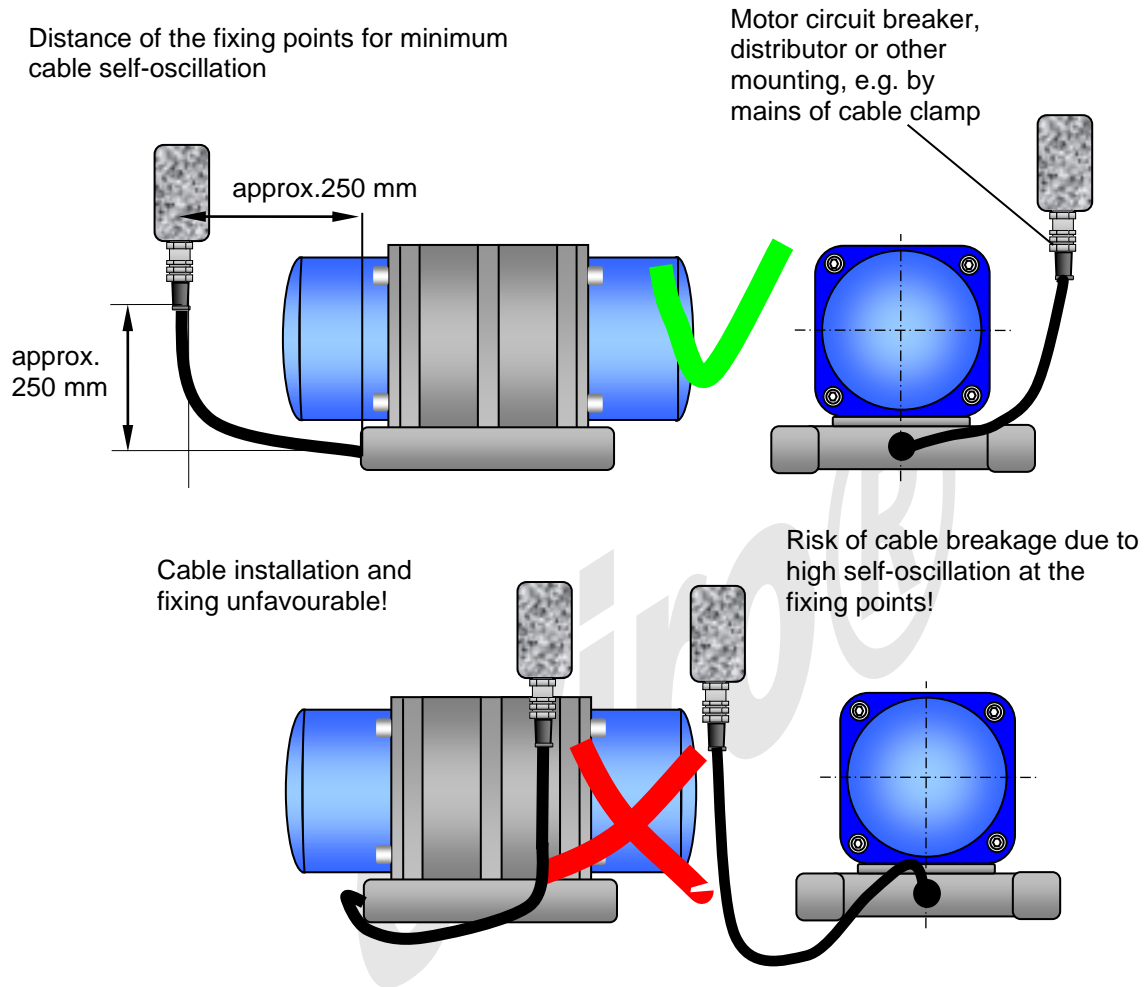

Figure 6 Cable installation connection line

5. Operating manual

5.1. Safe operation / safe function

<p>▲ WARNING</p>	<p>Vibration motors may only be put into operation when</p> <ul style="list-style-type: none"> ⇒ The motors were securely attached on a mechanically stable surface acc. to section 4.3.1 of this manual, ⇒ The electrical connections were installed securely according to section 4.3.2 of this manual ⇒ The mechanical safety devices were mounted properly. <p>Do not touch the vibration motors during operation! Allow motors to cool down after switch-off! Risk of burning!</p>

The tight fit of the screws has to be checked regularly during operation, for the first time after an operating time of approx. 24 hours.

When commissioning the motor, the power consumption and the housing temperature have to be monitored. If the motor current exceeds the value specified on the type plate (see Figure 1 Type plate), or if the housing temperature exceeds a value of 90 °C after a warm-up time of 30 minutes, it is likely that there is a

disharmony in the dynamic system of the vibration unit due to which the vibration motor is unable to reach its rated speed. The electric driving power and the set centrifugal force of the vibration motor, as well as the vibration behaviour of the vibration unit have to be synchronized. The vibration behaviour of the vibration unit is mainly determined by its spring damping system and its mass. By means of suitable constructional measures, the resonance behaviour of the overall system has to be designed in such a way that the drive can reach its rated speed. If necessary, the set centrifugal force of the vibration motor has to be decreased (see 5.3. Adjustment of the centrifugal force of the vibration motor).

If these measures are unsuccessful, the manufacturer will be happy to provide support with the handling of such issues.

Interventions in the motor which are not described in this manual are prohibited.

The protective covers provided by the manufacturer serve the protection against touching the rotating centrifugal weights during the operation of the vibration motor. In general, it is forbidden to operate the motor without special protective devices against the touching of rotating parts. If it is necessary to operate the vibration motor without protective covers for plant-specific reasons, the user has to take suitable constructional measures which achieve a protective effect similar to the covers.

5.2. Normal function

⚠ WARNING	<p>Due to the properties and the operating conditions of the machine at which the vibration motor is assembled, the allowed noise levels according to the national regulations might be exceeded. In this case, the operating personnel have to wear suitable ear protection.</p>
	

Due to construction, the rated speed of the vibration motor depends on the frequency of the operating voltage. Therefore, it is possible to adjust the frequency, working torque and centrifugal force of the generated vibrations to the operating conditions via a variation of the frequency of the operating voltage using a frequency converter. In doing so, the values indicated on the type plate (see Figure 1 Type plate) specify the allowed maximum values. It must be ensured that the maximum values of operating voltage and supply frequency specified on the type plate are never exceeded!

5.3. Adjustment of the centrifugal force of the vibration motor

The centrifugal force which can be generated with the vibration motor can be adjusted by changing the position of the centrifugal weights on the rotor shaft in discrete steps. Upon delivery, the centrifugal weights are factory-adjusted to the maximum centrifugal force specified on the type plate. If it is necessary to change this presetting, this is possible by assembling individual centrifugal weights turned by 180°. It must be observed that the centrifugal weights at both sides of the motor have to be assembled in the same number. In order to do so, the protective covers of the

drive have to be removed on both sides and the clamping screws of the centrifugal weights on the rotor shaft have to be loosened.

Per centrifugal weight to be turned at each side, the maximum centrifugal force will reduce by the values listed below, in dependence on the rotational speed.

Motor version	Reduction factor (f) when turning 1 centrifugal weight per side
Rated speed 1000 min ⁻¹	0,045kN
Rated speed 1500 min ⁻¹	0.1kN
Rated speed 1800 min ⁻¹	0.14kN
Rated speed 3000 min ⁻¹	0.41kN
Rated speed 3600 min ⁻¹	0.59kN
Rated speed 6000 min ⁻¹	1.65kN

The centrifugal force can be reduced in discrete steps by turning individual centrifugal weights (same number at both sides). Maximum half of the centrifugal weights may be turned, which results in a centrifugal force of 0 kN.

Table 4 Adjustment of the centrifugal force

⚠ WARNING	It is not allowed to adjust centrifugal force to higher values than shown on type plate. This could force damages in vibrating motor and/or in the equipment the motor is mounted on.
	

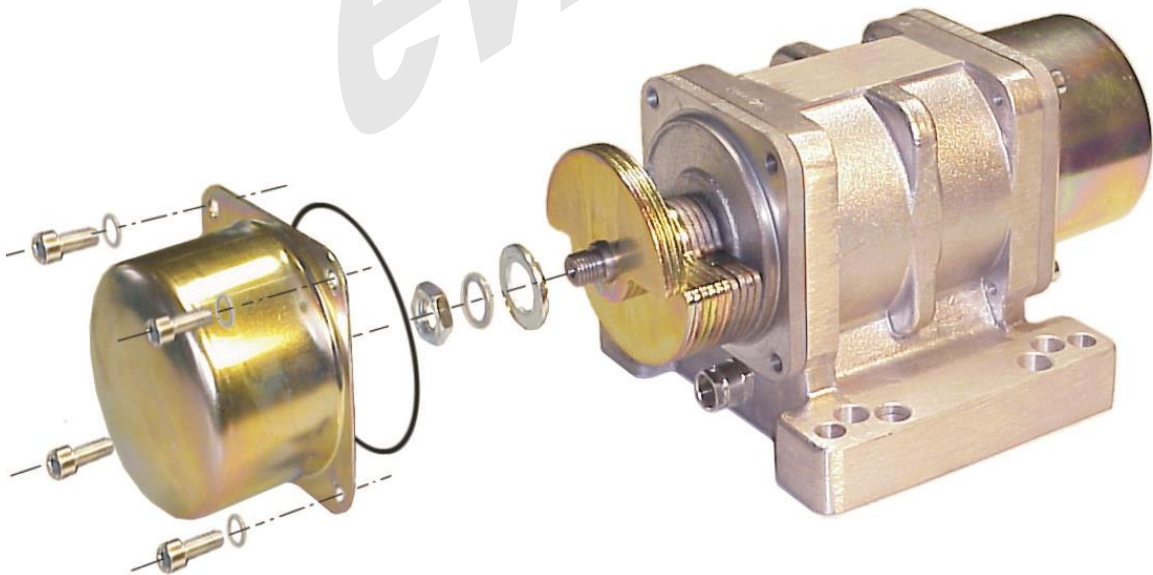





Figure 7 Adjustment of centrifugal weights

After the adjustment, the centrifugal weights have to be re-attached on the rotor shaft, new lock washers have to be inserted, and the protective covers have to be attached. Before attaching the protective covers, the intactness of the sealing rings has to be ensured. Damaged seals have to be replaced. The tightening torques of the screw connections of centrifugal weights and covers have to be observed (see Table 3 Required tightening torques for screws).

NOTE	Safety elements must not be re-used after their disassembly and have to be replaced with new ones!
	

6. Maintenance and repair

⚠ WARNING		<p>While plant components are active, avoid areas in which contact with moving parts of the machine might occur. Before entering such an area, the plant has to be switched off and a switch-off or securing process has to be carried out in accordance with the specifications of the plant manufacturer. Staying on plant components subject to vibration is strictly forbidden.</p> <p>Vibration motors can reach an operating temperature of 90 °C during operation. The vibration motor must not be touched during operation. Before touching it, switch off the motor and allow it to cool down! Risk of burning!</p>

	<p>Before carrying out any work at the vibration motor or the machine, plants and devices connected to the vibration motor, the mains connections have to be interrupted and secured against unintended re-connection.</p> <p>Metal surfaces which might be touched have to be earthed.</p>
---	---

NOTE	<p>The properties and the tight fit of all screw connections and fixtures at the vibration motor have to be checked regularly (min. after 24 operating hours). In order to do so, a suitable, calibrated torque wrench has to be used.</p> <p>The intactness of the electric cables and the safety of all electrical connections have to be checked as well.</p>
	

NOTE	
	The vibration motor has to be cleaned from dirt and depositions at regular time intervals in order to ensure sufficient cooling. Overheating caused by insufficient cooling can lead to the destruction of the vibration motor.

When observing the provisions of this manual, the operation of the vibration motors of the series A10 / AE10 / AEH10 / ANH10 is maintenance-free.



The cylindrical roller bearings are equipped with lifetime lubrication. Fittings for re-lubrication during the life cycle of the bearing are not required in this construction and therefore, not provided. The life cycle of the bearing depends on the operating conditions the vibration motor is exposed to. It is mainly influenced by ambient temperatures during operation, the mass ratios of the vibration unit, the loads due to interactions (vibration superimpositions) with other vibration motors (group operation), and rebound impacts of unaccelerated masses in the contact moment to the vibrating system. Therefore, the actual bearing life cycle can strongly deviate from the determined theoretical life cycle. The bearings have to be considered as wear parts whose life cycle depends on the operating loads.

The dimensioning of the bearings is constructed in such a way that 5000 operating hours should be achieved without problems. The theoretical life cycle is exceeded significantly in a large number of applications.

If irregularities occur during the operation of the motor, the motor has to be returned to the manufacturer with an error description which is as precise as possible. Any work for error diagnosis and repair may only be carried out by the manufacturer.

NOTE	
	Every intervention in the vibration motor which was not described in this manual will void the safety of the vibration motor and its conformity with the applicable guidelines, standards and rules. This leads to a loss of guarantee and releases the manufacturer from any liability for possibly occurred damages.

7. Decommissioning of the product

NOTE	
	
	Eviro vibration motors entirely consist of recyclable materials. Hence, at the end of the life cycle, the motors have to be recycled in a proper and professional manner, or returned to the manufacturer.

© eviro Elektromaschinenbau & Metall GmbH Eibenstock

All rights reserved. The figures diagrams and descriptions herein are the property of eviro. Duplication, even when only partial, is forbidden without written authorization from the manufacturer.

Annex 1

Exploded view

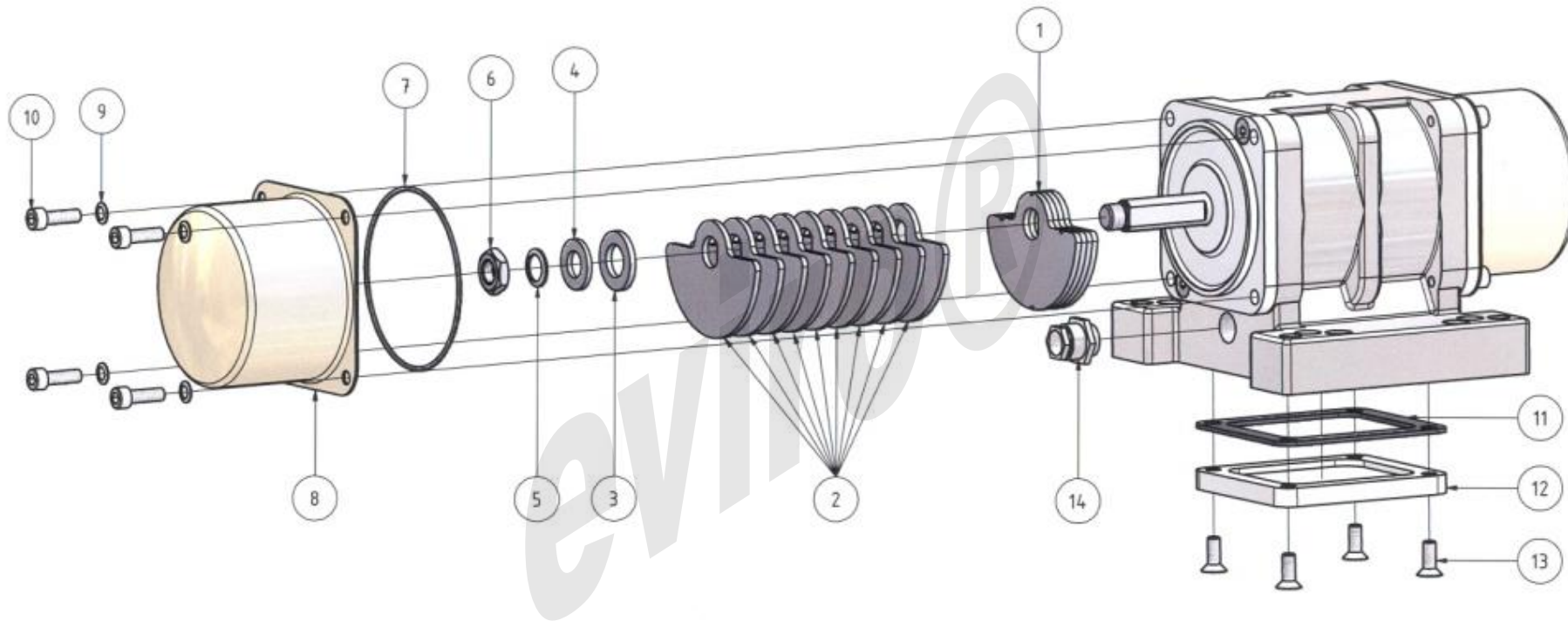

Annex 2 Spare parts list

Vibration motor A10 / AE10 / AEH10 / ANH10					
No.	Count	Type	Designation	Standard	Order number
1	2		centrifugal disc package 4 x design F		14.80.090.0231-1
2	4	A10-1,7-2/AE10-1,7-2 A10-2,8-2/AE10-2,8-2	Centrifugal disc design F.		14.80.100.0014-1
	18	A10-3,7-2/AE10-3,7-2 A10-5,4-2/AE10-5,4-2			
	20	A10-4,2-2/AE10-4,2-2 A10-6,0-2/AE10-6,0-2 / A10-5,8-6			
	32	A10-5,8-4/AE10-5,8-4 A10-9,0-4/AE10-9,0-4 / A10-8,3-6			
	8	AEH 10-7,8-4 ANH 10-7,8-4			
3	2	only A10-5,4-2	washer ST 16	DIN 125	14.01.042.08030137-01
4	2		washer A13 (M12) 140 HV	DIN 125	14.01.042.08020163-01
5	2		schnorr lock washer S12		*)
6	2		hexagonal nut BM 12x 1,5	DIN 439	*)
7	2		o-ring 82x2 - N - NBR 70	DIN 3771	*)
8	2	A10-1,7-2/AE10-1,7-2 A10-2,8-2/AE10-2,8-2	protective hood 83,2/44		14.80.100.0015-1
8	2	A10-5,8-4/AE10-5,8-4 A10-9,0-4/AE10-9,0-4 / A10-8,3-6	protective hood 83,2/80		14.80.100.0017-1
8	2	all others	protective hood 83,2/64		14.80.100.0016-1
9	8		schnorr lock washer S6		*)
10	8		hexagonal socket head cap screw M6 x 20	DIN 912	*)
11	1		washer of cover of terminal box		*)
12	1		cover of terminal box		14.80.061.0000
13	4		countersunk socket screw M6 x 20	DIN 7991	*)
14	1		screw connection 6kt M16 x 1,5		14.80.002.67071111
	1		component parts fuse members A10		14.80.000.0009
	1		bag for electrical circuit points		**) 14.80.000.0001

*) included in Set lock washers A10 14.80.000.0009

**) included by delivery without mains cable.

Annex 3 Declaration of conformity

EG-Konformitätserklärung

EC Declaration of Conformity

gemäß EG-Richtlinie Maschinen 2006/42/EG Anhang II Teil 1A

according to EC Directive 2006/42/EC, Annex II Part 1A

Der Hersteller
The manufacturer

eviro Elektromaschinenbau & Metall GmbH Eibenstock
Muldenhammer Straße 5
D-08309 Eibenstock

erklärt hiermit, dass die nachstehend bezeichneten Maschinen
hereby declares that the following machines

Bezeichnung: **Rüttelmotor**
Designation: Vibrating motor

Typen: **A10, AE10, AEH10, ANH10**
Types

ab Seriennummer: **16nnnnnn**
from serial number

in ihrer Konzeption und Bauart sowie in der von ihm in Verkehr gebrachten Ausführung den grundlegenden Sicherheitsanforderungen folgender EG-Richtlinien entsprechen:
in their design and construction as well as in the version which they have been placed on the market, complies with the essential safety requirements of the following EC Directives:

Richtlinien:
Directives

2006/42/EG (Maschinenrichtlinie)
2006/42/EC (Machinery Directive)

2014/35/EU (Niederspannungsrichtlinie)
2014/35/eu (Low Voltage Directive)

2014/30/EU (EMV-Richtlinie)
2014/30/eu (EMC Directive)

Angewandte harmonisierte
Normen:
Applied harmonized standards

**EN ISO 12100-1, EN ISO 12100-2, EN 60034,
EN 60 204-1**

Angewandte nationale
Normen und technische
Spezifikationen
Applied national standards and
technical specifications

DIN 57100

Die Einhaltung der Bedingungen der Richtlinie 2014/30/EU (EMV-Richtlinie) setzt einen EMV-gerechten Einbau der Produkte und die Beachtung der spezifischen Installationshinweise in der Produktdokumentation voraus.

Compliance with the requirements of Directive 2014/30/eu (EMC Directive) requires EMC-compliant installation of the products and observance of specific installation instructions in the product documentation.

Bei einer nicht mit dem Hersteller abgestimmten Änderung des Produktes verliert diese Erklärung ihre Gültigkeit.

In the case of a modification of the product which is not coordinated with the manufacturer, this declaration loses its validity

Eibenstock, den 01.04.2016

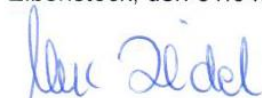

Ullus Leidel
Geschäftsführer
General Manager

eviro®
Elektromaschinenbau & Metall GmbH Eibenstock
Stempel Muldenhammerstraße 5
Company stamp 08309 Eibenstock
Tel. 03 77 52 / 30 13 oder 30 35
Fax 03 77 52 / 30 57